



**0.4
mm**

Detector

**900
pcs. / min**

Performance

**200
Watt**

X-ray source

X-RAY INSPECTION

RAYCON D+ HX LW

The high-end model of the intelligent curtainless X-ray inspection system for light or sharp-edged packaged products

- Conformity & Accuracy
- Safety for people & product
- Simple operating concept
- Hygienic design concept
- Efficiency in all areas
- Reliable and fast service

YOUR PRIORITIES, OUR ANSWERS:

Optimum X-ray inspection with the 6P concept

Our X-ray systems have been specially developed for use in the food industry and reliably detect foreign bodies such as metals, as well as glass, ceramics, stones, raw bones, PVC and many other product defects. Through this precise inspection, conformity with all important guidelines of the food industry such as IFS, BRC or FSSC 22000 is fulfilled and reliable protection against complaints and recalls can be ensured. The RAYCON D+ HX LW is curtainless and therefore especially suitable for light or sharp-edged products.

RAYCON exceeds international standards:



New software filters

The newly developed software filters improve the detection accuracy of foreign bodies with lower density. The Glassincreaser, for example, optimizes the detection of glass fragments, while the Bonedetector improves the detection of bone and cartilage. In addition, the Wirefinder can reliably detect smaller elongated wire forms.

Sensitivity prediction

The sensitivity prediction allows an automatic determination of the detection sensitivity of stainless steel and glass. The 100s of test cards made of glass and stainless steel are stored in the software in all sizes. They are calculated with the gray value image of the product as if a product with test card would actually be recorded.

Self-monitoring

„Integrated Compliance Monitoring“ ensures that the specified sensitivities are continuously checked at predefined time intervals. This control of detection requirements leads to immediate detection of deviations and increases the stability of the production process.

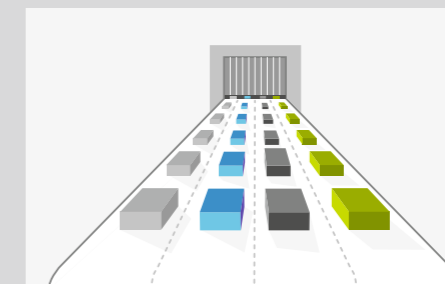
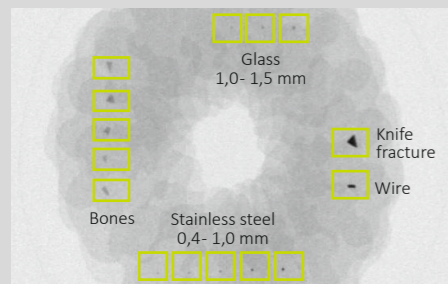
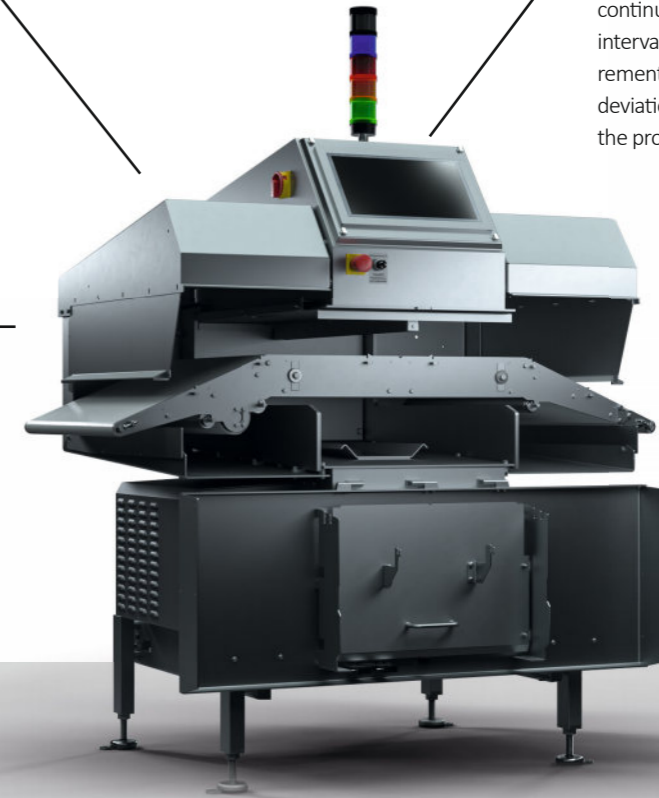

⌘P1 Conformity & Accuracy

Reliable detection of metallic and non-metallic foreign objects throughout the inspection area enables compliance with all current specifications and standards.

- RAYCON D+ HX LW X-ray inspection equipment offers detection accuracy from 0.3 mm stainless steel, better than the 0.8 mm required by IFS
- In addition, no blind spot even with tall products (bottom-up X-ray inspection).
- Optimal traceability through complete logbook and optional image archiving (Insight.NET or INTERLINK)
- UL/CSA certified

⌘P2 Safety for people & product

Thanks to highly effective radiation protection and dosed use of X-rays, the RAYCON D+ HX LW enables all-round safe operation for people and products.

- X-ray radiation for operators is less than 0.1 μ Sv/h, which eliminates the need for documentation of operating times
- When a cover is opened, the X-ray radiation is switched off and the pneumatic system is vented
- The X-ray inspection equipment can be used without any concerns even for organic products
- RFID login: maximum access protection

⌘P3 Simple operating concept

Thanks to a large touchscreen, easy-to-understand user guidance and features such as the Auto-Learn function, the RAYCON D+ HX LW offers particularly easy handling in everyday use.

- An Auto-Learn function makes operation very simple and intuitive
- Multi-product software enables automatic inspection of different products on one line
- Automatic edge detection adapts the filter to the product contours. In addition, the RAYCON automatically sets the optimal X-ray power for maximum detection accuracy during the learn-in process (Auto KV).
- RFID login for increased ease of use

⌘P4 Hygienic design concept

The open, modular design and the possibility of access to the conveyor area without tools simplifies cleaning and maintenance.

- No radiation curtains required – eliminates risk for re-contamination after cleaning and reduces operating costs
- Complete construction in stainless steel and plastics with suitability for the food industry (according to EG1935/2004)
- The materials are designed in such a way that they can be cleaned repeatedly and intensively without without abrasion. Water runs off automatically due to beveled surfaces.
- Conveying area: Protection class IP66

⌘P5 Efficiency in all areas

Thanks to high speeds and multi-lane capability, up to 900 products per minute can be inspected in real time – on a maximum of four parallel lines.

- Durable and sophisticated core components with 200 W X-ray source and 0.4 mm high-resolution detector
- Automatic detection of X-ray source lifetime (early warning system for plannable source replacement)
- Highest search sensitivity through Zone Analyzer software: free zone selection within the X-ray image
- Reliable detection of additional product defects such as missing, broken or deformed products
- ECO Mode

⌘P6 Reliable and fast service

With warranty services, a combined on-site and remote service, and targeted training, you have optimal support for smooth operation.

- Wear and spare parts packages for fast resumption of production
- Remote service via Teamviewer / Pilot App
- Customer-specific training for operation, radiation protection and service/maintenance
- High overall system efficiency and stable operation
- Lifetime warranty with the Sesotec Lifetime Warranty package

Functional diagram

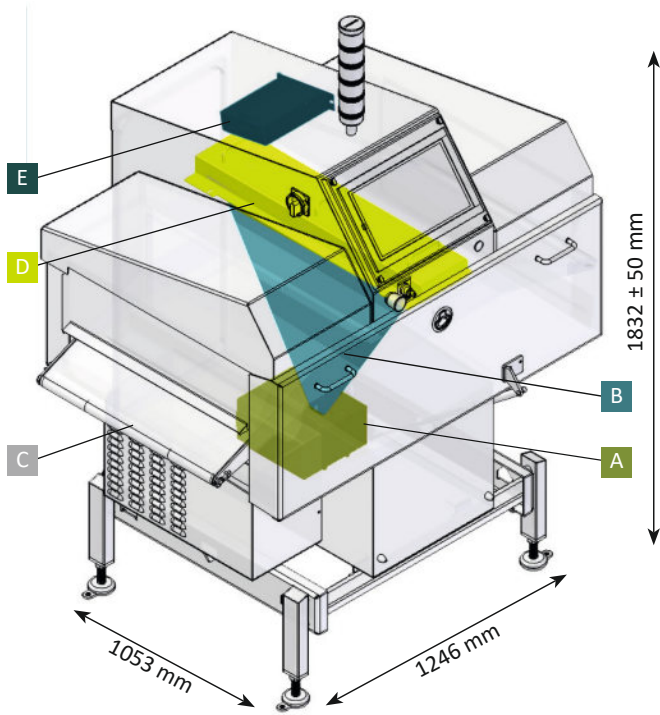

The system consists of the following main components:

- A** X-ray tube: Here the X-rays are generated electrically. It exits the tube through a narrow slit and penetrates the product to be examined from the bottom to the top as a fan-shaped beam.
- B** X-ray beam
- C** Transport system: A PE flat belt (self-guiding) transports the product to be examined evenly through the X-ray beam. This makes it possible to scan the product line by line.
- D** Detector unit: The linear detector installed above the inspection aperture converts the incoming X-ray beams into an electrical signal from which a digital X-ray image is generated.
- E** Industrial PC: This is where image evaluation and precise control of the reject systems take place.

Detection performance

The detectability of foreign bodies in X-ray systems with single-energy technology depends primarily on the density of the foreign body. All foreign bodies with a density significantly higher than the product density are very well detectable. These include, for example, metals, glass, stones, ceramics in products such as sausage, cheese, meat, etc. However, thanks to the high-resolution detector and the sophisticated software evaluation using a large number of filters in the RAYCON D+ HX LW, bones, rubber, Teflon, PVC, etc. can also be reliably detected. A free test with your product provides you with a meaningful basis for decision-making.

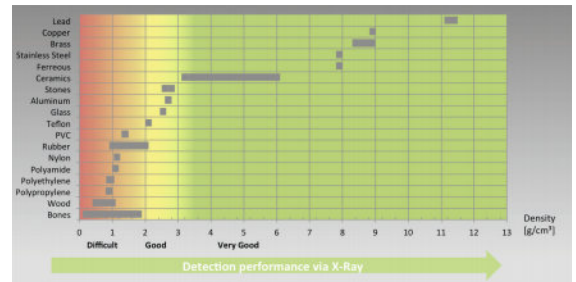

The RAYCON Family

RAYCON D+ MX LW

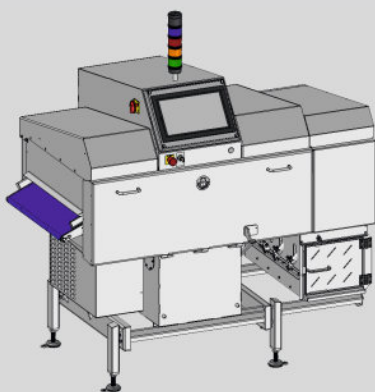

The standard curtainless model of the RAYCON family with high precision from 0.6 mm for light or sharp-edged packaging with a product height below 50 mm.

RAYCON D+ HX LW

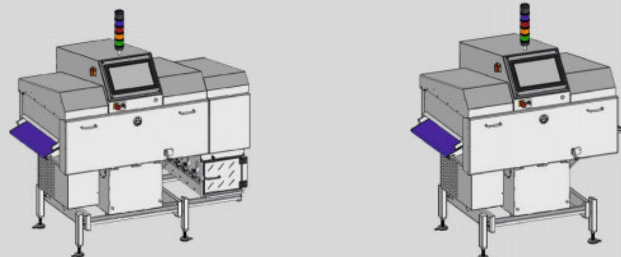

Belt width: 360 mm

X-ray source:
40 - 60 KV / 3.3 - 5.0 mA (200W)

Detector: 0.4 mm

Max. Inspection area (W x H):
330 x 50 mm

Variations: signal only, separated or integrated reject system with 1 or 2 flaps

Belt width: 660 mm

X-ray source:
40 - 60 KV / 3.3 - 5.0 mA (200W)

Detector: 0.4 mm

Max. Inspection area (W x H):
630 x 50 mm

Variations: signal only, separated or integrated reject system with 1 or 2 flaps